

10 N Screw Flat Grips

10 N (2.2 lbf) screw flat grips are primarily used for tensile testing low force, soft materials such as yarn, paper, plastics, and cloth, in film or wire geometry. Grip faces are flat and rubber-coated, and the supplied coupling joints for the 10 N screw flat grips are designed for use on lower-capacity load cells. A notch in the upper grip helps center materials such as yarn.

The upper coupling includes a hook that screws directly into the load cell and an S-shaped universal joint onto which the upper grip hooks. The lower grip mounts directly on the lower joint of the main unit.

These grips are supplied with a coupling that connects with AG-X plus series 5 kN (1,100 lbf) and lower-capacity load cells. Additional load cell coupling parts are required for the AGS-X and EZ-X series and are listed as accessories.

Relevant Materials

Yarn, Paper, Plastics, Cloth

Relevant Specimens

Plates, Films, Wires



Operation

To clamp a specimen within the grip faces, knurled knobs on both the upper and lower grips are finger tightened. As the grips close, one grip face moves horizontally toward the other stationary grip face.

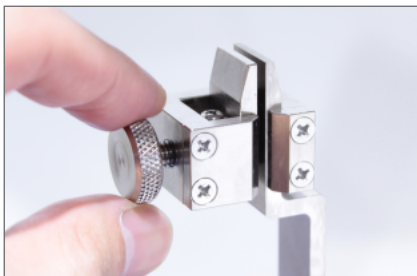

Finger tightened grip



Gripping of yarn in the upper grip is helped by the notch



Lower gripping of yarn with tension

Specification

Maximum Grip Capacity			Applicable Specimen Thickness	Grip Face Size		Temperature Range	Grip Size		Upper Grip Mass	Upper Fitting Note 2	Lower Ø Fitting (Ø pin)
				Width	Length		Width	Length Upper / Lower Note 1			
N	kgf	lbf	mm (in)	mm (in)	mm (in)	°C (°F)	mm (in)	mm (in)	kg (lb)	mm	mm
10	1.0	2.2	0 to 3 (0 to 0.12)	16 (0.63)	15 (0.59)	-10 to 60 (14 to 140)	16 (0.63)	100 / 145 (3.9 / 5.7)	0.083 (0.18)	M12 screw, 1.5 pitch	16 (6.5)

Note 1: The upper grip length includes the length of the S-shaped universal joint.

Note 2: The load cell coupling is applicable to 5 kN or lower AG-X plus load cells. Additional coupling joints are required when these grips are used with AGS-X series and EZ-X series load cells.

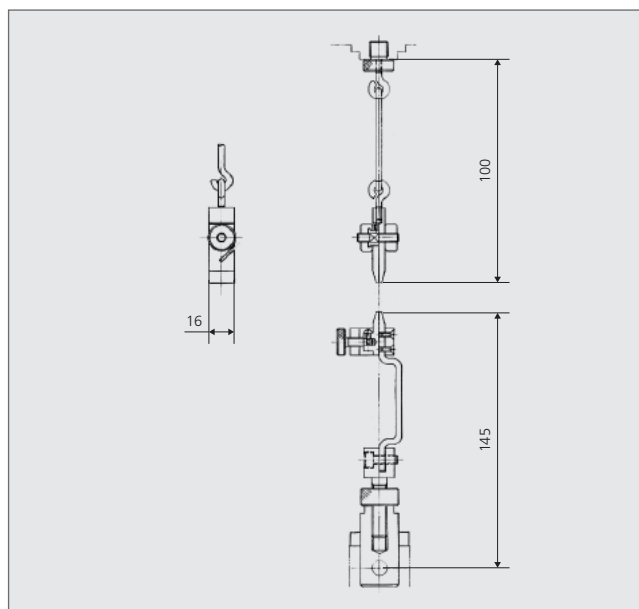

Ordering Information

P/N	Description
344-13427-10	10 N Screw Flat Grip Set Includes: upper and lower grips with flat rubber-coated grip faces, an S-shaped upper joint, and a load cell coupling for AG-X plus series 5 kN and lower capacity load cells
Accessories	
022-60295-31	Load cell coupling for AGS-X series load cells between 10 N and 100 N capacity and EZ-X series load cells between 10 N and 500 N capacity
343-38279-05	Load cell coupling for AGS-X series 500 N capacity load cells

Second Edition: May, 2015



Company names, product/service names and logos used in this publication are trademarks and trade names of Shimadzu Corporation or its affiliates, whether or not they are used with trademark symbol "TM" or "®". Third-party trademarks and trade names may be used in this publication to refer to either the entities or their products/services. Shimadzu disclaims any proprietary interest in trademarks and trade names other than its own.

For Research Use Only. Not for use in diagnostic procedures. The contents of this publication are provided to you "as is" without warranty of any kind, and are subject to change without notice. Shimadzu does not assume any responsibility or liability for any damage, whether direct or indirect, relating to the use of this publication.