

Precision Universal Testing Machines

# AUTOGRAPH AGX-V Series



# *This is the AGX-V.*

At Shimadzu, our aim is to develop instruments that provide the highest level of test results.

To this end, we created the AGX, the highest class of testing machine in the industry.

It features a high rigidity frame; multi processors, high-speed sampling and high-accuracy automatic control; an intelligent crosshead; stroke limit switches; a high degree of safety; a smart controller equipped with a progressive user interface; and software that supports the creation of test conditions and data processing with intuitive operability.

Shimadzu has been manufacturing testing machines for more than 100 years.

The AGX series is the culmination of the continuous evolution of the AUTOGRAPH based on our wealth of experience and achievements, and insights from customers around the world.

## *Three Features*

### **01** Aggregation of Cutting-Edge Functions

▶▶ Page 04-07

### **02** True Safety for Both the Operator and the Machine

▶▶ Page 08-09

### **03** Operability that Takes the Shortest Path to Results

▶▶ Page 10-11

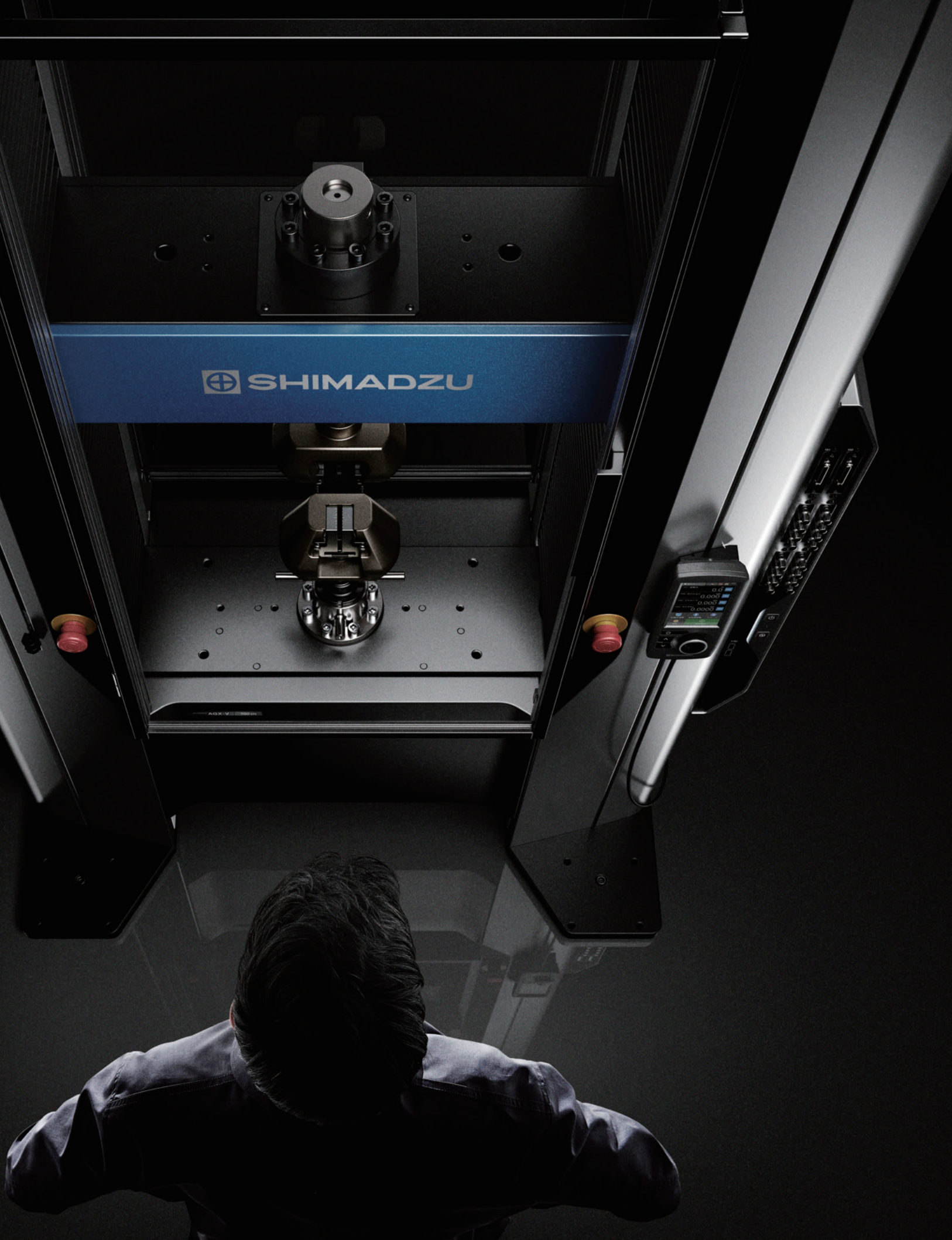

 SHIMADZU

0.0  
0.000  
0.0000

# 01 Aggregation of Cutting-Edge Functions

## Revolutionary Technology Provides Full Control

Ultra-high-speed  
data sampling

Ultra-high-response  
crosshead control

**10 kHz × 1 kHz**

Equipped with Multi Processors and Multi Engines,  
Providing Ultrafast Data Acquisition and  
High Response Control

Shimadzu's proprietary control box is equipped with two processors and three engine units. It provides 1 kHz high response crosshead control and 10 kHz high-speed data sampling through high-level simultaneous parallel processing, based on a meticulous timing design, and the allotment of various communications, measurement, and control functions across multiple devices.

Leave Strain Rate Control to the Machine  
by Utilizing New Autotuning

High-accuracy control is maintained under noisy, highly disturbed conditions, something that was hard to provide with conventional autotuning.

This high-level autotuning is achieved by using not only feedback measurement values but all measurement values in the calculations for real-time updates of the control model.

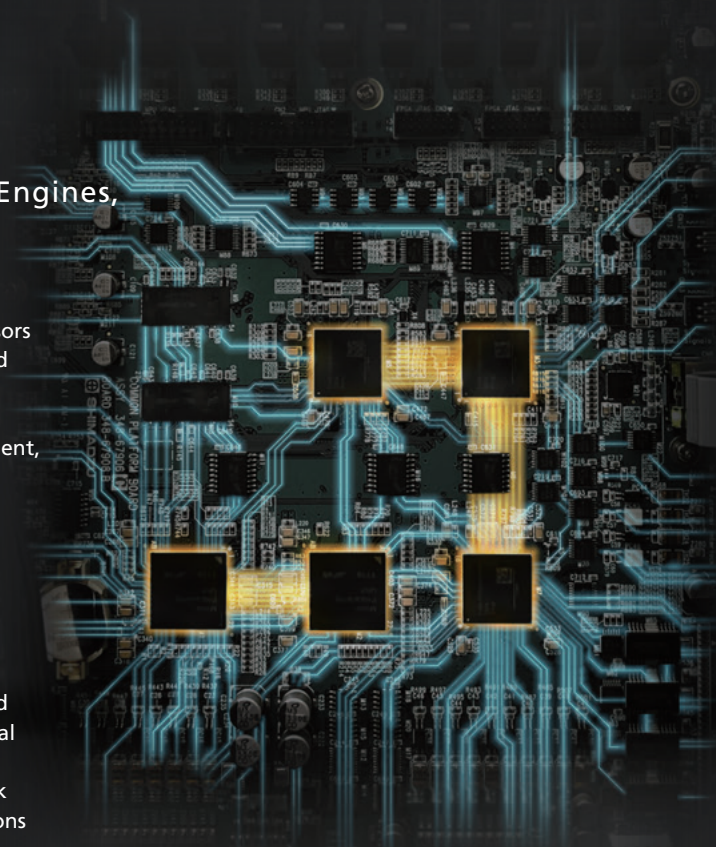
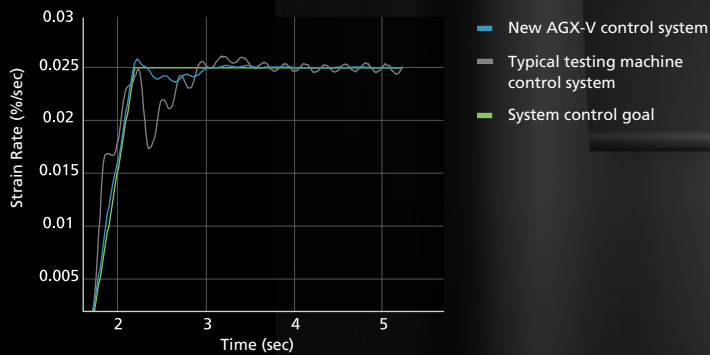

## Steel and Nonferrous Metal Testing

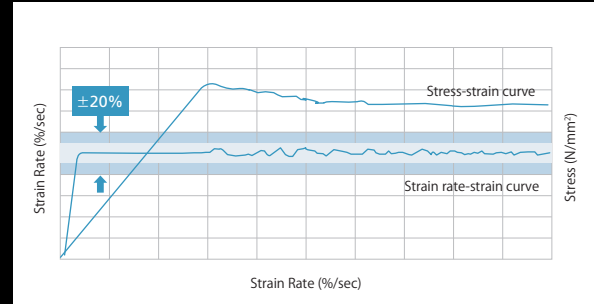
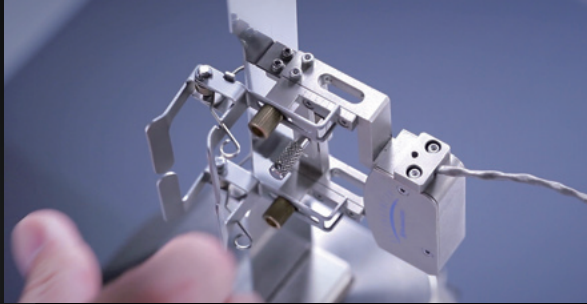

Strain rate control, in which the rate of deformation measured by an extensometer is controlled to be constant, requires highly accurate control to follow rapid changes in material behavior.

Metal Tensile Test Standard: ISO 6892 (JIS Z 2241) specifies that the allowable range of increase in strain to the yield point is  $\pm 20\%$  or less. The strain rate control specified in ISO 6892 (JIS Z 2241) is possible\*<sup>1</sup> to achieve with the AGX-V for many materials.

## Practical Simulation Testing

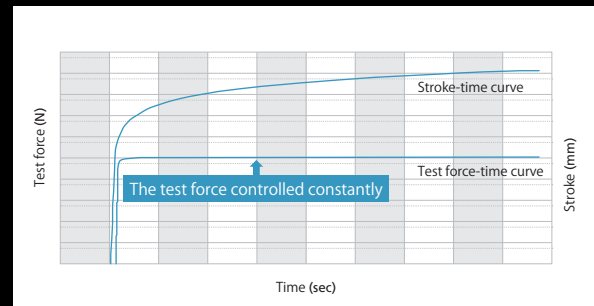

To maintain engine mounts and other rubber materials at a constant test force, it is necessary to gradually change the retention position to suit the characteristics of the test sample. In order to maintain the test force at a constant value, high control stability is required, with high control responsiveness and no vibrations generated due to excessive response.\*<sup>2</sup>

## Free Running Compression Testing

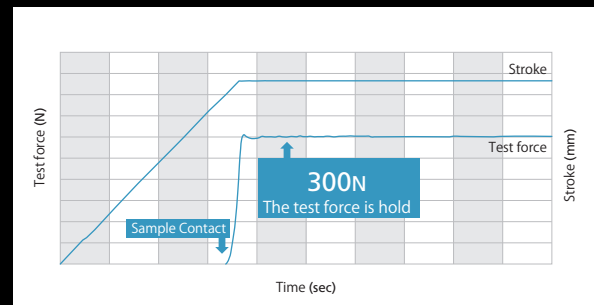
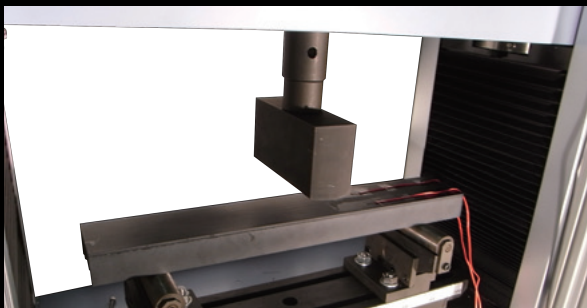

Stable control is achieved even in free running compression tests. In these tests, the compression indenter or bending punch is allowed to run free until it makes contact with the sample, at which point the load is increased up to a set test force.

The overshoot of the target value is kept to 1 % or less of the indicated value even in free running compression tests of highly rigid materials, resulting in a high-accuracy test force retention.\*<sup>2</sup>

\*<sup>1</sup> The graph is an example. The control accuracy may vary depending on the material properties and the surrounding environment. It does not guarantee accuracy.

\*<sup>2</sup> The graph is an example. The state of control can vary depending on the material properties and the surrounding environment.

# Wider Range, More Detail, More Variety

Ultra-high-speed data sampling

## 10 kHz

### Captures Instantaneous Changes

The ultra-high-speed sampling function has progressed up to a sampling rate of 10 kHz (0.1ms). Sudden and tiny changes, such as when brittle materials break, can now be assessed.

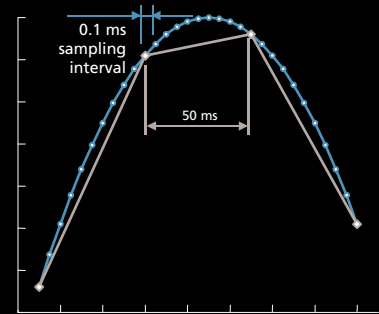

Ultra high-speed data sampling

Guaranteed test force range

## 1/2000

### Reduces the Frequency of Load Cell Replacement

The guaranteed test force accuracy range has been enlarged to 1/2000 for an even wider range of data reliability. Even data from the very beginning of the test force application can be analyzed with confidence. Tests that previously required multiple load cell replacements to suit the test force are now supported by a single load cell, cutting back on replacement procedures and calibration expenses.

Maximum number of sensor inputs

## 20 ch

### All the Data Are Synchronized and Acquired with High Accuracy A Data Logger is Not Required

The external input ports can be expanded to 20 channels. Analog input units and counter units can be selected, making it easy to acquire more data without a data logger.

The load cell, extensometer, and external input ports are synchronized, and all channels are sampled simultaneously, improving the simultaneity of the data. This further improves the accuracy and reliability of the elastic modulus and other data calculated using two or more measurement values.

Load amplifier  
(sensor amplifier)

4 channel analog  
input unit

Digital input unit

PIO unit

Sensor amplifier

## Equipped with a Multi Joint\*1

### Improved Operational Safety and Efficiency

The replacement of joints and heavy test jigs is now unnecessary as small-capacity load cells can be attached. This reduces the workload and risks involved in handling heavy objects, and can reduce replacement procedures.

### ASTM Class 10 Shaft Alignment Guaranteed, an Industry First\*2

This machine provides CLASS 10 shaft alignment accuracy, as prescribed in ASTM E1012. High shaft alignment accuracy heightens data reliability for high strength materials and composite materials.

### Rigid Joint Included as Standard

A rigid multi joint (fixed type) has been adopted in place of the typical universal joint. In addition to improving safety and convenience, the shaft alignment accuracy has also been improved, improving measurement repeatability.

### Frame Design Provides High Rigidity and High Level Alignment

The newly designed guide column\*2 is equipped with a support ring\*2 that maintains a right angle with the table surface. As a result, measurement repeatability has been improved in tests of high rigidity materials and highly brittle materials, prone to the impact of frame rigidity or alignment, enabling stable testing.

\*1 Available table-top and floor models range from 300 kN to 20 kN.  
\*2 Only floor models from 300 kN to 20 kN are supported.  
Axial accuracy is guaranteed when the Shimadzu trial clamp and test specimen are connected to the main body of the tester.  
The guaranteed accuracy range is up to the frame capacity (AGX -300 kN up to 100 kN).



## 02 True Safety for both the Operator and the Machine

### Safety Cover

#### Protects Operators from Debris

Highly transparent, impact-resistant polycarbonate safety covers are provided as standard for the front and rear of the test space. This prevents samples from flying out when they break. An interlock function is provided, so that if the safety cover is not closed, testing and the return operation are prevented, reducing the risk of accidents.

- Using optional accessories, all movement including the jog operation can be prohibited.



## Intelligent Crosshead

### Prevents Jig Impacts

The intelligent crosshead always recognizes its current position. If the jigs get too close due to an operational error, an impact warning is issued, and the crosshead is stopped automatically.

### Contact Detection and Instantaneous Emergency Stop

The machine status is diligently monitored even when the crosshead is moved with the safety cover open, such as when adjusting the position of test jigs or attaching samples. If the machine detects the test force changes due to contact with jigs or hands, the crosshead performs an emergency stop.

### Overload Detection Function

If the machine detects a test force exceeding the load cell capacity, the crosshead stops automatically. This reduces the risk of load cell damage from overloads during the jog operation and during testing. (Note that the possibility of damage cannot be completely eliminated.)



## Stroke Limit Switch

### Pinch, Position, and Release Grips

A stroke limit switch, which sets the limits of crosshead movement, prevents crosshead and jig impacts. A spring mechanism within the switch reliably sets the position when the hand is released, preventing configuration errors due to procedural mistakes such as insufficient tightening.



Stroke Limit for Floor Types



Stroke Limit for Table-Top Types

## Self Check Function

### Machine's Self-Diagnostic Function

The function constantly monitors sensor amplifier calibration information, the operational status of the testing machine, the power supply voltage, and the communications status. The user is immediately notified when a problem occurs. Additionally, the usage time and number of uses of the machine are checked, and a notification is issued when prescribed values are reached. This assists with the assessment of maintenance periods and helps reduce downtime.

(It does not detect offsets in measurement values from load cells and extensometers due to age-related changes. Periodic maintenance and inspections by a field engineer are recommended.)

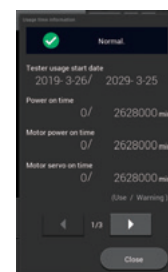

# 03 Operability that Takes the Shortest Path to Results



## All Jigs are Easily Connected

The multi joint, which connects jigs to load cells, enables all jigs, including tensile, compression, and bending jigs, to be connected easily. The replacement of heavy joints is no longer needed, which simplifies the replacement of test jigs. A small-capacity load cell can be connected to the tip, so tests with small-capacity load cells can be performed with a large-capacity load cell attached as is.

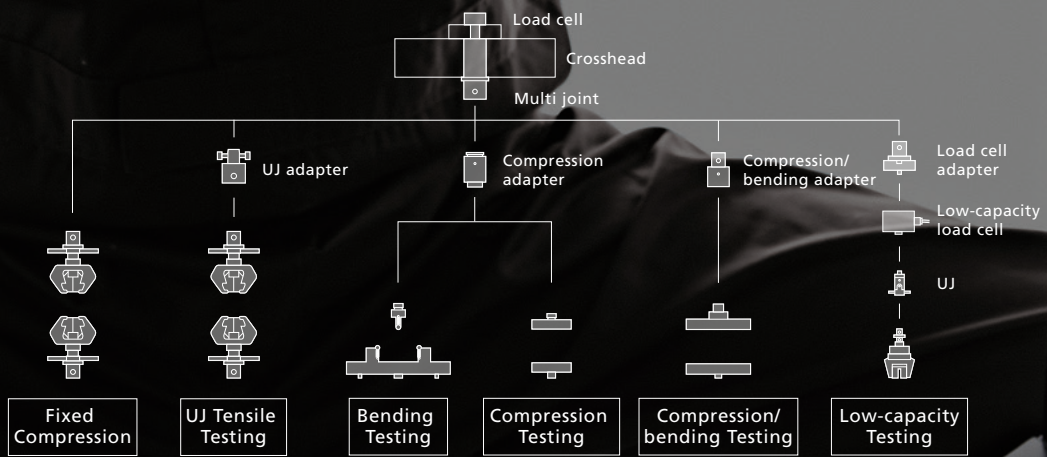

## Smart Controller

The controller is equipped with a touch panel LCD, which displays the optimal buttons and information for the situation. It shows a variety of operations and informational displays, including jig space adjustments prior to testing and confirmation of measurement values during tests. A universal interface standardized with the software has been adopted to support all kinds of testing by high operability and visibility.

## Selection of operation sound according to environment

The special AUTOGRAPH operational sounds are adjustable. Select from a pleasant sound quality enhancing operational comfort or a sound that is easy to hear even in noisy conditions. (The sound can also be turned OFF.)

## Voice alerts

A voice message warns the operator before the crosshead moves, preventing mistakes by the operator. (The sound can also be turned OFF.)



## Finish Settings and Operations with a Hand-Held Controller

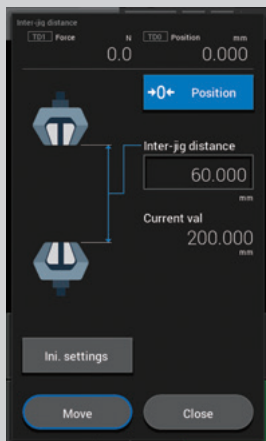

### Configure Optimal Grip Space Automatically

With the intelligent crosshead function, the crosshead moves to ensure a user-defined jig separation. The jig separation is constantly monitored to prevent impacts between jigs. (The jigs must be pre-registered.) Additionally, the jig separation movement can be performed automatically in accordance with the test conditions by interlinking it with TRAPEZIUMX-V.

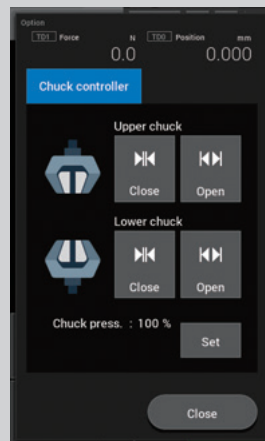

### Perform the Opening/Closing of Grips from a Single Controller

Using a hand-held controller, both pneumatic and hydraulic type grips can be opened and closed automatically. This controller improves productivity since everything needed to prepare for measurements, from crosshead movement and testing conditions settings to hydraulic adjustments, can generally be implemented.

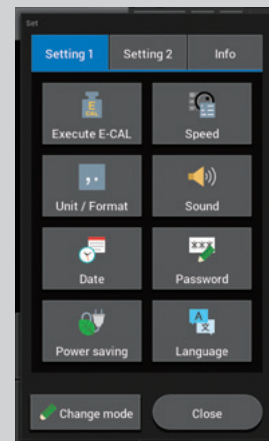

### Check Detailed Settings with a Hand-Held Controller

The user can check the overview of the test conditions, set the sound, configure power saving settings, and set the system language. In addition to improving operational efficiency, pop-ups that check operations prior to movement reduce the risk of operational mistakes.

# TRAPEZIUMX-V

## Achieves Both Simplicity and High Level Functionality

The software ensures that anyone can easily use the AGX-V, which is equipped with a number of cutting-edge functions. With a flexible UI that accommodates a variety of testing situations, the software is suitable for all users.

### Select from Five Software Programs

#### Single Software



This software is used to perform typical single-direction tests. It enables performing tensile, compression, and bending testing.

#### Cycle Software



This software enables performing endurance testing and other tests that involve repeated application of test forces.

#### Control Software

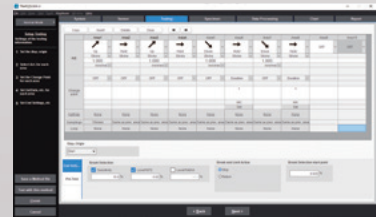

This software enables creating a user-specified testing machine movement routine. It allows tests to be performed in which foam rubber is compressed and held repeatedly.

#### Texture Software

This software enables measuring the properties (texture) of foodstuffs and pharmaceuticals. Special data processing results, including mastication, jelly strength, and adhesion, can be obtained.

#### Spring Software

This software enables the testing of springs. Both the characteristic values specific to springs and the spring height and length can be measured.

## Visual Wizard Provides Guidance for Setting Parameters with Confidence

- Parameter settings can be specified while viewing the overall sequence using the test parameter wizard.
- Easy-to-understand illustrations are used in windows for specifying parameters for test control, samples, and data processing. Specifying settings is now very easy.



Software Wizard for Specifying Parameters for Sample and Data Processing



## Better, More Flexible Reporting

- Report Designer with Flexible Layout  
You can create reports with test results, graphs, photos, logos, and more. Items on the report can be arranged and sized as desired. The font, color, and border of each item can also be set finely.
- Output reports in PDF, Microsoft Word®, Excel®, and HTML formats  
Reports created in the Report Designer can be output in a variety of formats. Customize reports the way you want with familiar software.

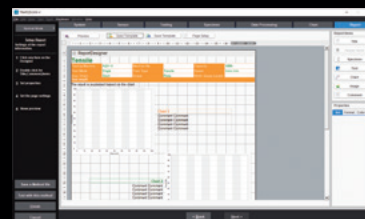

## Worry-free Features Ensure Data Reliability

### More Reliable Data Management by User Control, Operational Logs, and Automatic Data Transfer Functions

- With the user login function, limits on functionality can be established for each user.
- If the network transmission function is used, the test results can be transferred automatically to a host system when the test is finished. The software is also capable of reorganizing the data in the file to transfer.
- The software has an event log and an operational log function.
- The size of the sample can be read in from electronic calipers, and the sample name can be read in from a bar-code reader.



### USB Camera Function Provides Evidence of Testing

- Using a camera with a USB connection, videos interlinked with the start and end of tests can be recorded.
- Samples can be observed with a video playback function interlinked to the stress-strain curve.
- Still images excised from the video can be pasted into reports as test evidence.



USB camera (Options)

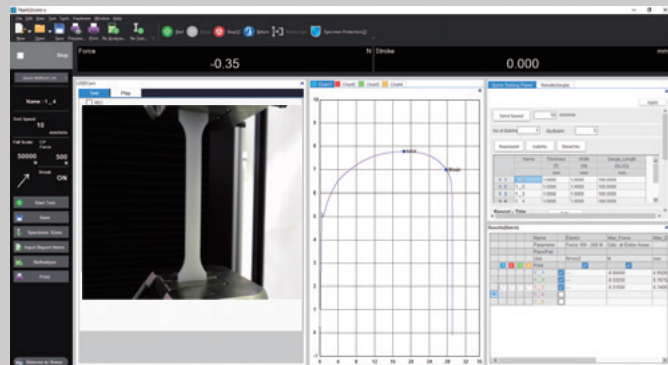

## Support for Difficult Settings

### Easy Conditions Settings Mode Ensures that Anyone Can Start Testing Immediately

The absolute minimum number of settings is gathered together, so tests can be implemented with no confusion. After the test, the test results can be analyzed in detail using the recalculation functions.

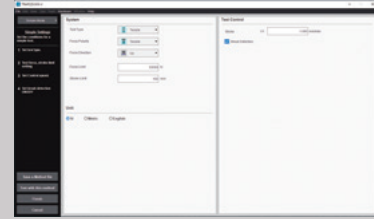

### Automatic Calculation of the Elastic Modulus with No Parameters Required

The elastic modulus, an important evaluative index for material testing, is calculated automatically with no parameter settings required.

Even unknown materials with unknown characteristics can be tested with confidence.

The logic behind the calculations is based on methods recommended in ISO6892-1 (2016) Annex A.

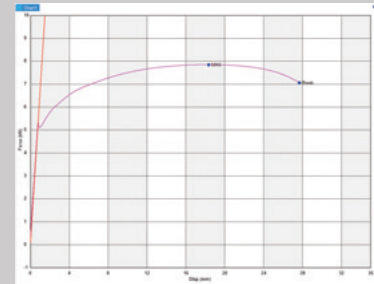

## Convenient Features Save Time and Effort

### Off-Line Analysis Function Makes Efficient Use of Time Even During Testing

A second instance of the software can be started up off-line during testing. Even in the midst of long tests, the conditions for the next test can be created, and previous results can be analyzed, which saves time.

### Quickly Verify Test Control with High-Speed Sensors

Data on strain rates, stress rates and other speeds can be displayed while being calculated in real time. Data that had been determined manually after testing can be calculated automatically, and users can check at a glance that the control accuracy prescribed by regulations is being satisfied.

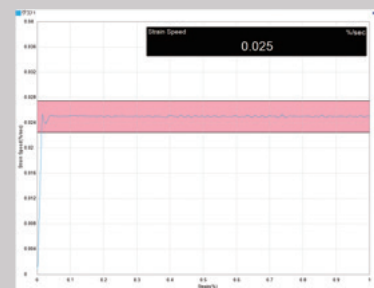

### Web Applications Enable Users to Check Results from Remote Locations

Thanks to applications that run in a specially designed web browser, test result files can be accessed from tablets and other mobile devices.

Results can be checked from an office, even when that office is distant from the laboratory.



# Ensuring High Accuracy Measurements of Strengthened Materials

Higher accuracy testing control is required when testing materials being strengthened for the purpose of reducing the weight of transportation equipment. The combination of AGX-V's high response real-time autotuning function with the external noise-resistant AEH-3HR automatic extensometer functions effectively in strain rate tests as per the ISO 6892 (JIS Z2241) metallic materials test standards. Additionally, for aging tests in which characteristic values are calculated based on two sets of test results, the functions built into the TRAPEZIUMX-V software reduce the number of calculations performed manually.



SHIMADZU



## AEH-3HR High-Accuracy Automatic Extensometer

This ISO 9513 Class 1 compatible extensometer can measure elongation across a full range of tests, from measuring the modulus of elasticity to the breaking elongation. In combination with the AGX-V series machine, this high-resolution extensometer is compatible with the ISO 6892 strain control requirements.



## HFG Hydraulic Flat Grips (100 kN, 300 kN, 600 kN)

These hydraulic flat grips provide high rigidity and a stable grip force. Opening or closing the grips and changing the grip force can be performed from the smart controller. They are equipped with a sample attachment guide and, in addition, a specially designed hydraulic power source has been adopted, which saves energy through intermittent operation.

## MWG Manual Non-Shift Wedge Grips

With these manual grips, turn the handle to grasp the sample. These are popular, cost-effective grips. By replacing the grip teeth, they can accommodate not only flat sheets of material, but also tests of rods.



## DT Differential Transformer Extensometer

This extensometer is used for strain measurements of metals, hard plastics, and other samples with comparatively small elongation. In combination with the AGX-V series, it is compatible with electric calibration, which improves user friendliness.

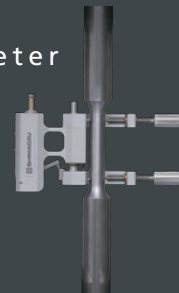

## High-Temperature Test Device

This furnace is for high-temperature tests of heat-resistant alloys and ceramics. In combination with a special extensometer, it is compatible with strain measurements and strain control. Select from a lineup featuring a duplex unit that makes the most of the test cycle time, an IR lamp furnace capable of high-speed heating, and a unit with a temperature range up to 1500 °C.

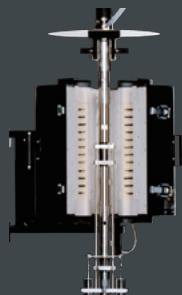

## Low-Temperature Test Device

For tests of brittleness, low-temperature immersion tanks for implementing bending tests in liquid nitrogen, and cryostats for creating ultra-low-temperature environments can be created. Tests can be implemented at -196 °C.

• Some of these instruments require special optional parts to connect to a testing machine. Contact your Shimadzu representative.

# Improving the Efficiency of Low to Medium Capacity Tests

It is important to control the temperature and humidity conditions when testing materials affected by these conditions. Shimadzu offers a variety atmospheric control testing machines, including refrigerator and gas injection types, to suit the objective. Additionally, the AGX-V's high-speed return function reduces the standby time during long stroke tests, shortening the test cycle time. Combining switch-operated grips and automatic extensometers further reduces the cycle time.



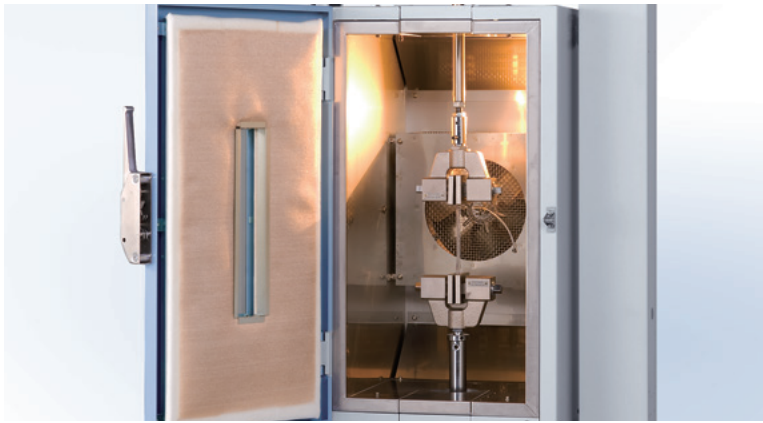

## Device for Atmosphere Tests

Instruments are available for tensile, compression, and bending tests performed in environments not at normal temperatures, including everything from low-temperature to high-temperature environments.

## SIE Automatic Extensometer SIE-560A/560SA

This extensometer is equipped with various automatic functions. It automatically detects the grip positions, and moves the elongation measurement arm to a point between the grips. It releases from the sample automatically when the test is finished and returns to the default position, so after attaching the sample, the operator can entrust all the operations to the testing machine, which functions semi-automatically. The lineup also includes a high-accuracy type with a measurement accuracy of  $\pm 1 \mu\text{m}$ .

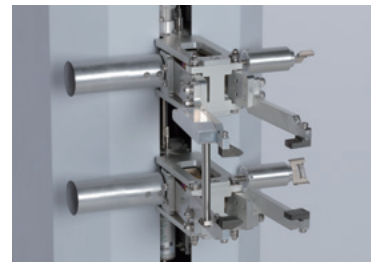

## PFG Pneumatic Flat Grips

With these grips, a foot switch and an interlocked air chuck unit that starts testing automatically after the sample is gripped are selectable. The grips can maintain a stable force even when gripping soft samples that change thickness at the gripped part during testing.



## SG Series Strain Gauge Type Extensometer

This is widely used as a manual extensometer. Various types are available depending on the need, including conformity with grades in ISO, JIS, ASTM, and other standards, gauge lengths, and tests under high-temperature conditions.



## TRViewX Video Type Non-Contact Extensometer

This is a high-accuracy non-contact extensometer that measures the sample strain from captured images. It can accommodate everything from general materials to films that a contact extensometer cannot be attached to directly.



## Bending Deflection Gauge

This deflection gauge for bending tests conforms with ISO 178 and JIS K7171. The displacement gauge is pressed against the lower surface of the sample. The indentation depth on the sample during testing is then measured with high accuracy.

The gauge is equipped with a mechanism that cancels the force used to press the displacement gauge, so it has no effect on the test force measurement.

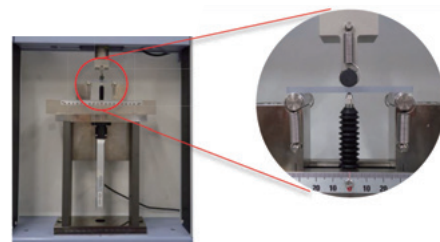

• Some of these instruments require special optional parts to connect to a testing machine. Contact your Shimadzu representative.

# Improving Design, Development, and Analysis Capacities

Validation & Verification (V & V) is required for high-precision simulation, and tests are conducted to load actual products.

The auto-tuning function, which maintains the test force with high precision, the analog input function of up to 20 channels, and the WEB camera function are effective for these tests. You can also choose special test jigs to improve the accuracy of the simulation.



 SHIMADZU

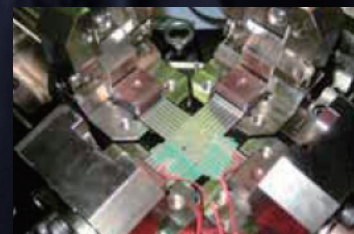

## Biaxial Tensile Testing

Biaxial tensile tests can be implemented for samples in accordance with ISO 16842. The tensile ratio can be changed by exchanging parts.

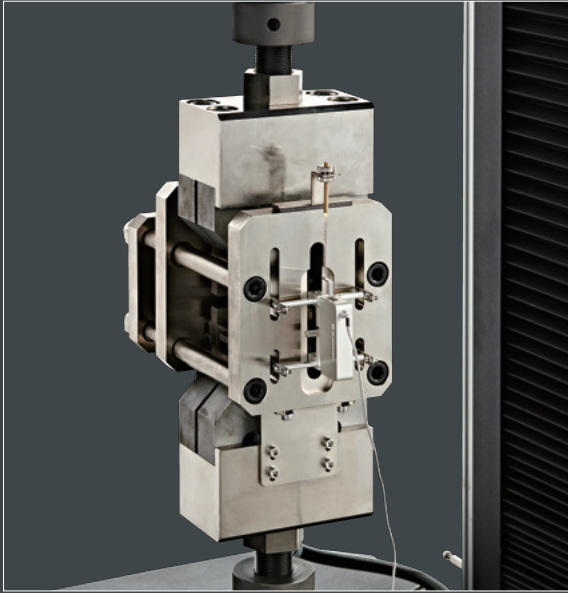

## In-Plane Reversing Testing (Measurements of the Bauschinger Effect)

Plate materials are stretched in the longitudinal direction. After plastic deformation, the loading direction is reversed, and they are compressed in the longitudinal direction. The system can perform tests so that the plate materials do not buckle when force is applied again in the tensile direction.



## Actual Object Testing

Compression plates and surface plates enable tests to be performed with a load applied to large parts and assemblies. Actual object testing can be used not only for strength evaluations but to confirm the results of simulations.

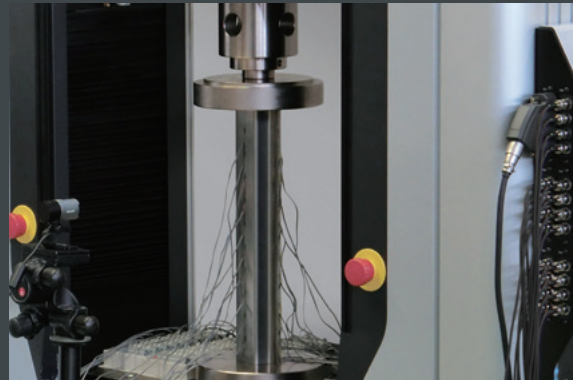

## DIC Analysis

DIC analysis is a method of investigating the amount of deformation of a body by applying a random pattern to the surface of the body and comparing the pattern before and after deformation. The strain distribution can be mapped in two dimensions without using a complex optical system. By adding this function to the TRViewX video type non-contact extensometer, image and video files ideal for DIC analysis can be output. (The DIC analysis software is not included. Please order it separately.)

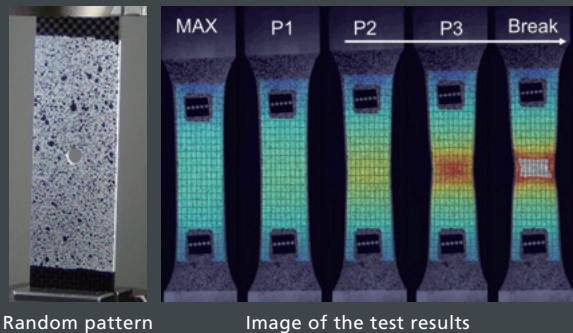

• Some of these instruments require special optional parts to connect to a testing machine. Contact your Shimadzu representative.

# Applications to New Materials

In the field of new materials development, including composite materials, unique tests are required in order to evaluate the strength of adhesive bonding between different types of materials, and the lowering of strength due to scratches. Our lineup includes items compliant with ISO and JIS as well as ASTM standards, and optional instruments such as a shaft alignment instrument as an entire testing system are also available. Additionally, with ultra-high-speed sampling, a function of the main unit, even abrupt reductions in test force when highly brittle materials break are not overlooked.



## PAS Shaft Alignment System

This instrument measures the alignment of a standard sample from the test axis using an attached strain gauge, and then performs adjustments to minimize the small deviation. It is possible to secure a core of ASTM E 1012 Class 8 or higher.

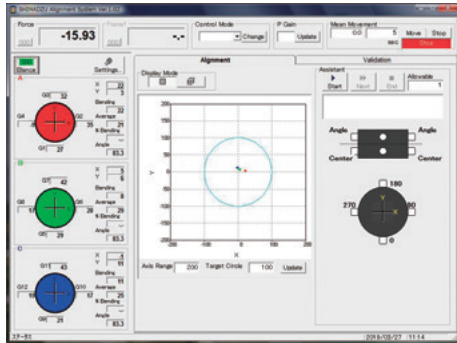

## Combined Loading Compression Test Jig (CLC Test, ASTM D6641)

This is for a test method that combines shear load and end face load.

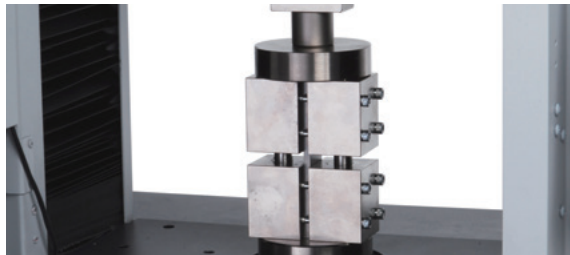

## Jig for Evaluating Compression Residual Strength Properties (ASTM D7137)

This is for a compression test on a sample that has been damaged in an impact test.

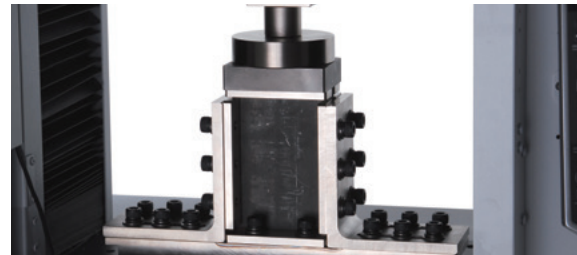

## MMB Test Jig (ASTM D6671)

This is for measuring interlaminar breakage in CFRPs, and can be used to perform a test with mixed mode I (opening mode) and mode II (in-plane shear mode).

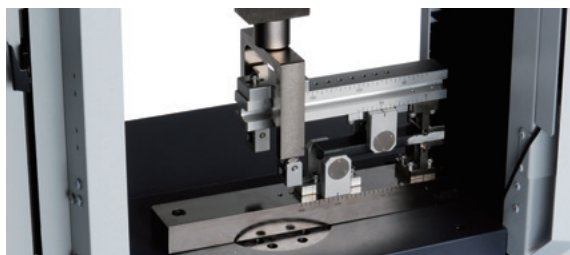

## Double V-Notched In-Plane Shear Test Jig (Iosipescu Method, ASTM D5379)

This is for measuring in-plane shear strength, in-plane shear fracture strain, and the in-plane shear elastic modulus.

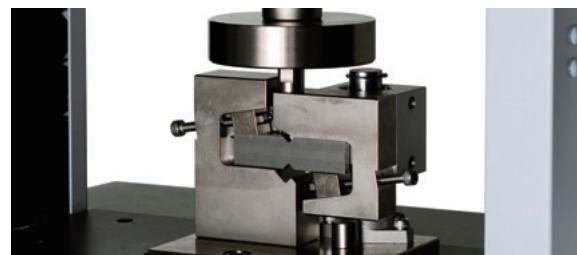

## V-Notched Rail Shear Test Jig (ASTM D7078)

This is for a shear test of a sample with 90° V-notches on the top and bottom.



## Open Hole Compression Test Jig (OHC Test, ASTM D6484)

This is a compression test jig for an open hole test sample that has a circular hole in the center.

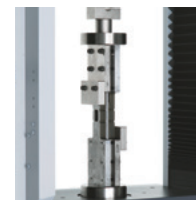

• Some of these instruments require special optional parts to connect to a testing machine. Contact your Shimadzu representative.



AGX-10kNVD



AGX-50kNVD



AGX-50kNV

## System Specifications

Model Name		AGX-10kNVD	AGX-20/50kNVD	AGX-20/50kNV
Max. Loading Capacity		10 kN	50 kN	
Loading Method		AC servomotor drive		
Test Force Measuring Range*1	High-Accuracy Type	Within $\pm 0.5\%$ error of the indicated test force (in a range from 1/1000 to 1/100 of the load cell rated capacity) Within $\pm 0.3\%$ error of the indicated test force (in a range from 1/100 to 1/1 of the load cell rated capacity) Compatible with JIS B7721 Class 0.5, EN 10002-2 Grade 0.5, ISO 7500-1 Class 0.5, BS 1610 Class 0.5, DIN 51221 Class 0.5, and ASTM E4		
	Wide Ranging Type	Within $\pm 1\%$ error of the indicated test force (in a range from 1/2000 to 1/1000 of the load cell rated capacity) Within $\pm 0.5\%$ error of the indicated test force (in a range from 1/1000 to 1/100 of the load cell rated capacity) Within $\pm 0.3\%$ error of the indicated test force (in a range from 1/100 to 1/1 of the load cell rated capacity) Compatible with JIS B7721 Class 1, EN 10002-2 Grade 1, ISO 7500-1 Class 1, BS 1610 Class 1, DIN 51221 Class 1, and ASTM E4		
	Standard-Accuracy Type	Within $\pm 1\%$ error of the indicated test force (in a range from 1/1000 to 1/1 of the load cell rated capacity) Compatible with JIS B7721 Class 1, EN 10002-2 Grade 1, ISO 7500-1 Class 1, BS 1610 Class 1, DIN 51221 Class 1, and ASTM E4  Within $\pm 1\%$ error of the indicated test force (in a range from 1/500 to 1/1 of the load cell rated capacity) Compatible with JIS B7721 Class 1, EN 10002-2 Grade 1, ISO 7500-1 Class 1, BS 1610 Class 1, DIN 51221 Class 1, and ASTM E4		
Crosshead Speed Range*2		0.0005~3000 mm/min	0.0005~1500 mm/min	0.00005~1500 mm/min
Maximum Crosshead Return Speed		3000 mm/min	2000 mm/min	
Crosshead Speed Accuracy		$\pm 0.1\%$		
Crosshead Speed and Permitted Test Force		Up to the maximum load capacity for all speed ranges		
Crosshead Position Detection	Measurement System	Battery-less multi-turn absolute encoder		
	Positional Accuracy	Within $\pm 0.05\%$ of the indicated value, but $\pm 0.01$ mm when the indicated value is below 20 mm		
Crosshead Position Control Resolution		12.5 nm	8.33 nm	
Crosshead-Table Clearance (mm) (Tensile Stroke)*3	Standard Height	180 to 1150 (0 to 550)	200 to 1150 (20 kN:0 to 840 mm, 50 kN:0 to 780 mm)	215 to 1265 (20 kN:0 to 860 mm, 50 kN:0 to 800 mm)
	+250 mm Extension	180 to 1375 (0 to 775 mm)	200 to 1375 (20 kN:0 to 1065 mm, 50 kN:0 to 1015 mm)	215 to 1490 (20 kN:0 to 1085 mm, 50 kN:0 to 1025 mm)
	+500 mm Extension	180 to 1600 (0 to 1000 mm)	200 to 1600 (20 kN:0 to 1290 mm, 50 kN:0 to 1230 mm)	215 to 1715 (20 kN:0 to 1310 mm, 50 kN:0 to 1250 mm)
	+750 mm Extension	—	—	215 to 1940 (20 kN:0 to 1535 mm, 50 kN:0 to 1475 mm)
Effective Test Width		420 mm	500 mm	600 mm
Data Capture Rate		10 kHz max.*6		
Frame Rigidity	Direction of Tension	60 kN/mm	180 kN/mm	
	Direction of Compression	60 kN/mm	180 kN/mm	
Standard Functions		<ul style="list-style-type: none"> <li>• Test force/stress value display</li> <li>• Stroke display</li> <li>• Test force auto zero</li> <li>• Test force auto calibration</li> <li>• Automatic loading of load cell characteristic values</li> <li>• Fine adjustment of crosshead position (Button/Dial)</li> <li>• Interlock function (Safety cover)</li> <li>• Touch load detection</li> <li>• Switching display languages to Japanese/English/Chinese language</li> <li>• Switching display unit</li> <li>• Standby Power Savings</li> <li>• Self-check</li> <li>• Auto return</li> <li>• Setting Jig distance</li> <li>• Test piece protection</li> <li>• Timer</li> <li>• Calculator</li> <li>• Light</li> <li>• Sound (Choose between standard and clear)</li> <li>• Audio Output (Japanese/English/Chinese)</li> <li>• 6 internal unit ports (One of the ports is dedicated to testing power.)</li> </ul> <p><b>When the displacement gauge is connected</b></p> <ul style="list-style-type: none"> <li>• Displacement/strain value display function</li> <li>• Displacement auto zero</li> <li>• Displacement auto-calibration (Displacement gauge input amplifier only)</li> </ul> <p><b>When TRAPEZIUMX-V is connected</b></p> <ul style="list-style-type: none"> <li>• Automatic test force/strain control (with autotuning function)</li> <li>• Breakage detection</li> <li>• Soft limit detection</li> <li>• Peak value/breakage value display</li> </ul>		
Optional Functions		<ul style="list-style-type: none"> <li>• Up to 5 optional units listed below can be installed.</li> <li>• Sensor amplifier (load cell, SG displacement meter, LVDT displacement meter), analog input amplifier (4CH), analog output amplifier (4CH), counter unit (4CH), PIO unit (16 inputs and 16 outputs), insulated PIO unit (16 inputs and 16 outputs), analog recorder unit</li> <li>• Pneumatic or hydraulic grips interlocking operation</li> </ul>		
Standard Accessories		Load cell, CAL cable, Tool set, Power supply cable, Rotating rod, Hexagon wrench, Instruction manual, Safety caution sheet (1 each)		
Model Lineup by Load Cell Capacity*4		10 N/20 N/50 N/100 N/500 N/1 kN/5 kN/10 kN	20 kN/50 kN	



Dimensions*5		Standard Height	W 798 × D 515 × H 1582 mm	W 975 × D 579 × H 1708 mm	W 1206 × D 765 × H 2170 mm
		+250 mm Extension	W 798 × D 515 × H 1832 mm	W 975 × D 579 × H 1958 mm	W 1206 × D 765 × H 2420 mm
		+500 mm Extension	W 798 × D 515 × H 2082 mm	W 975 × D 579 × H 2208 mm	W 1206 × D 765 × H 2670 mm
		+750 mm Extension	—	—	W 1206 × D 765 × H 2920 mm
Weight	Standard Height	100 V Model	210 kg	—	—
		200 V Model	210 kg	410 kg	640 kg
		400 V Model	—	—	650 kg
	+250 Extension	100 V Model	230 kg	—	—
		200 V Model	220 kg	420 kg	660 kg
		400 V Model	—	—	670 kg
	+500 Extension	100 V Model	240 kg	—	—
		200 V Model	230 kg	440 kg	680 kg
		400 V Model	—	—	680 kg
	+750 Extension	100 V Model	—	—	—
		200 V Model	—	—	690 kg
		400 V Model	—	—	700 kg
Power Supply/ Breaker Capacity Required		100 V Model (Single-Phase, 100 to 115 V)	1.5 kVA/15 A	—	—
		200 V Model (Single-Phase, 200 to 230 V)	2.0 kVA/10 A	5.5 kVA/30 A	—
		200 V Model (3-Phase, 200 to 230 V)	—	—	4.5 kVA/15 A
		400 V Model (3-Phase, 380 to 400 V)	—	—	4.0 kVA/10 A

\*1: In the JIS B7721, EN 10002-2, ISO 7500-1, and ASTM E4 standards, an inspection is recommended after the testing machine is installed.

\*2: The crosshead speed accuracy is calculated from the amount of crosshead movement within a specified time at a crosshead speed of 0.5 to 500 mm/min under normal conditions.

\*3: The tensile stroke indicates the value when manual non-shift wedge grips (MWG) or screw-type grips (SCG) are attached.

\*4: 10 N and 20 N are only for the standard-accuracy type.

\*5: During installation, ensure a space of 600 mm on each side and rear of the testing machine for maintenance.

\*6: Internal data sampling rate is 500kHz.

• Values in this catalog have been measured based on separately prescribed test standards.

• If small conductive sample fragments are produced, they might get inside the main unit, resulting in malfunctions. In such a case, contact your Shimadzu representative.

## Options

P/N	Description
339-90000-01	Exclusive Table, Height 650 mm, for the 10 kN Max. Table-Top Type
339-90000-02	Exclusive Table, Height 400 mm, for the 10 kN Max. Table-Top Type
339-90001-01	Exclusive Table for the 20/50 kN Table-Top Type
336-00313-01	Anti-Topple Attachment for the 10 kN Max. Table-Top Type
336-00313-02	Anti-Topple Attachment for the 20/50 kN Max. Table-Top Type
336-00311	Anti-Topple Attachment for the 20 to 300 kN Floor Type
336-00311-01	Anti-Topple Attachment for the 300 kN +750 Extension Floor Type
336-00311-02	Anti-Topple Attachment for the 600 kN Floor Type
336-01076-01	Sensor Amplifier
336-01076-07	Analog Input Amplifier
336-01076-04	Analog Output Amplifier
336-01076-05	Counter Unit
336-01076-03	PIO Unit
336-01076-02	Insulated PIO Unit
336-01076-08	Analog Recorder Unit
345-05842	X-TP Recorder
345-05843	X-TYP Recorder
346-55042	One-Touch Load Cell Replacement Function
346-55042-01	One-Touch Load Cell Attachment
336-01674-01	Safety Cover Offset 10kND STD
336-01674-02	Safety Cover Offset 10kND +250
336-01674-03	Safety Cover Offset 10kND +500
336-01674-11	Safety Cover Offset 50kND STD
336-01674-12	Safety Cover Offset 50kND +250
336-01674-13	Safety Cover Offset 50kND +500
336-01674-21	Safety Cover Offset 50/100kN STD
336-01674-22	Safety Cover Offset 50/100kN +250 / 300kN STD
336-01674-23	Safety Cover Offset 50/100kN +500 / 300kN +250
336-01674-24	Safety Cover Offset 50/100kN +750 / 300kN +500
336-01674-25	Safety Cover Offset 300kN +750
336-01073-13	USB camera stand 50 to 300 kN camera included
336-01073-12	USB camera stand 50 kND camera included
336-01073-11	USB camera stand 10 kND camera included



AGX-100kNV



AGX-300kNV



AGX-600kNV

## System Specifications

Model Name		AGX-100kNV	AGX-300kNV	AGX-600kNV
Max. Loading Capacity		100 kN	300 kN	600 kN
Loading Method		AC servomotor drive		
Test Force Measuring Range*1	High-Accuracy Type	Within $\pm 0.5\%$ error of the indicated test force (in a range from 1/1000 to 1/100 of the load cell rated capacity) Within $\pm 0.3\%$ error of the indicated test force (in a range from 1/100 to 1/1 of the load cell rated capacity) Compatible with JIS Compatible with JIS B7721 Class 0.5, EN 10002-2 Grade 0.5, ISO 7500-1 Class 0.5, BS 1610 Class 0.5, DIN 51221 Class 0.5, and ASTM E4		Within $\pm 0.5\%$ error % of the indicated test force (in a range from 1/500 to 1/1 of the load cell rated capacity) Compatible with JIS B7721 Class 0.5, EN 10002-2 Grade 0.5, ISO 7500-1 Class 0.5, BS 1610 Class 0.5, DIN 51221 Class 0.5, and ASTM E4
	Wide Ranging Type	Within $\pm 1\%$ error of the indicated test force (in a range from 1/2000 to 1/1000 of the load cell rated capacity) Within $\pm 0.5\%$ error of the indicated test force (in a range from 1/1000 to 1/100 of the load cell rated capacity) Within $\pm 0.3\%$ error of the indicated test force (in a range from 1/100 to 1/1 of the load cell rated capacity) Compatible with JIS B7721 Class 1, EN 10002-2 Grade 1, ISO 7500-1 Class 1, BS 1610 Class 1, DIN 51221 Class 1, and ASTM E4		—
	Standard-Accuracy Type	Within $\pm 1\%$ error of the indicated test force (in a range from 1/1000 to 1/1 of the load cell rated capacity) Compatible with JIS B7721 Class 1, EN 10002-2 Grade 1, ISO 7500-1 Class 1, BS 1610 Class 1, DIN 51221 Class 1, and ASTM E4		Within $\pm 1\%$ error of the indicated test force (in a range from 1/500 to 1/1 of the load cell rated capacity) Compatible with JIS B7721 Class 1, EN 10002-2 Grade 1, ISO 7500-1 Class 1, BS 1610 Class 1, DIN 51221 Class 1, and ASTM E4
	Within $\pm 1\%$ error of the indicated test force (in a range from 1/500 to 1/1 of the load cell rated capacity) Compatible with JIS B7721 Class 1, EN 10002-2 Grade 1, ISO 7500-1 Class 1, BS 1610 Class 1, and ASTM E4			
Crosshead Speed Range*2		0.00005 to 1500 mm/min	0.00005 to 720 mm/min	0.00005 to 540 mm/min
Maximum Crosshead Return Speed		1800 mm/min	720 mm/min	540 mm/min
Crosshead Speed Accuracy		$\pm 0.1\%$		
Crosshead Speed and Permitted Test Force		Up to the maximum load capacity for all speed ranges		
Crosshead Position Detection	Measurement System	Battery-less multi-turn absolute encoder		
	Positional Accuracy	Within $\pm 0.05\%$ of the indicated value, but $\pm 0.01$ mm when the indicated value is below 20 mm		
Crosshead Position Control Resolution		8.33 nm	3.33 nm	2.50 nm
Crosshead-Table Clearance (mm) (Tensile Stroke)*3	Standard Height	215 to 1250 (0 to 760)	215 to 1440 (0 to 630)	215 to 1650 (0 to 850)
	+250 mm Extension	215 to 1475 (0 to 985)	215 to 1665 (0 to 855)	215 to 1875 (0 to 1075)
	+500 mm Extension	215 to 1700 (0 to 1210)	215 to 1890 (0 to 1080)	215 to 2100 (0 to 1300)
	+750 mm Extension	215 to 1925 (0 to 1435)	215 to 2115 (0 to 1305)	215 to 2325 (0 to 1525)
Effective Test Width		600 mm		790 mm
Data Capture Rate		10 kHz max.*5		
Frame Rigidity	Direction of Tension	300 kN/mm	400 kN/mm	700 kN/mm
	Direction of Compression	300 kN/mm	400 kN/mm	600 kN/mm
Standard Functions		<ul style="list-style-type: none"> <li>• Test force/stress value display</li> <li>• Stroke display</li> <li>• Test force auto zero</li> <li>• Test force auto calibration</li> <li>• Automatic loading of load cell characteristic values</li> <li>• Fine adjustment of crosshead position (Button/Dial)</li> <li>• Interlock function (Safety cover)</li> </ul> <p><b>When the displacement gauge is connected</b></p> <ul style="list-style-type: none"> <li>• Displacement/strain value display function</li> <li>• Displacement auto zero</li> <li>• Displacement auto-calibration (Displacement gauge input amplifier only)</li> </ul>	<ul style="list-style-type: none"> <li>• Touch load detection</li> <li>• Switching display languages to Japanese/English/Chinese language</li> <li>• Switching display unit</li> <li>• Standby Power Savings</li> <li>• Self-check</li> <li>• Auto return</li> <li>• Setting Jig distance</li> </ul>	<ul style="list-style-type: none"> <li>• Test piece protection</li> <li>• Timer</li> <li>• Calculator</li> <li>• Light</li> <li>• Sound (Choose between standard and clear)</li> <li>• Audio Output (Japanese/English/Chinese)</li> <li>• 6 internal unit ports (One of the ports is dedicated to testing power.)</li> </ul> <p><b>When TRAPEZIUMX-V is connected</b></p> <ul style="list-style-type: none"> <li>• Automatic test force/strain control (with autotuning function)</li> <li>• Breakage detection</li> <li>• Soft limit detection</li> <li>• Peak value/breakage value display</li> </ul>

Optional Functions		<ul style="list-style-type: none"> <li>Up to 5 optional units listed below can be installed. Sensor amplifier (load cell, SG displacement meter, LVDT displacement meter), analog input amplifier (4CH), analog output amplifier (4CH), counter unit (4CH), PIO unit (16 inputs and 16 outputs), insulated PIO unit (16 inputs and 16 outputs), analog recorder unit</li> <li>Pneumatic or hydraulic grips interlocking operation</li> </ul>			
Standard Accessories		Load cell, CAL cable, Tool set, Power supply cable, Rotating rod, Hexagon wrench, Instruction manual, Safety caution sheet (1 each)			
Model Lineup by Load Cell Capacity		100 kN	300 kN	600 kN	
Dimensions**4	Standard Height	W 1206 × D 765 × H 2170 mm	W 1206 × D 765 × H 2420 mm	W 1605 × D 1122 × H 2840 mm	
	+250 mm Extension	W 1206 × D 765 × H 2420 mm	W 1206 × D 765 × H 2670 mm	W 1605 × D 1122 × H 3090 mm	
	+500 mm Extension	W 1206 × D 765 × H 2670 mm	W 1206 × D 765 × H 2920 mm	W 1605 × D 1122 × H 3340 mm	
	+750 mm Extension	W 1206 × D 765 × H 2920 mm	W 1206 × D 765 × H 3170 mm	W 1605 × D 1122 × H 3590 mm	
Weight	Standard Height	100 V Model	—	—	
		200 V Model	780 kg	950 kg	
		400 V Model	790 kg	970 kg	
	+250 Extension	100 V Model	—	—	—
		200 V Model	810 kg	980 kg	3020 kg
		400 V Model	810 kg	990 kg	—
	+500 Extension	100 V Model	—	—	—
		200 V Model	830 kg	1000 kg	3070 kg
		400 V Model	840 kg	1020 kg	—
	+750 Extension	100 V Model	—	—	—
		200 V Model	850 kg	1030 kg	3130 kg
		400 V Model	860 kg	1050 kg	—
Power Supply/ Breaker Capacity Required	100 V Model (Single-Phase, 100 to 115 V)	—	—	—	
	200 V Model (Single-Phase, 200 to 230 V)	—	—	—	
	200 V Model (3-Phase, 200 to 230 V)	6.5 kVA/20 A	7.5 kVA/30 A	13.0 kVA/40 A	
	400 V Model (3-Phase, 380 to 440 V)	5.0 kVA/10 A	6.5 kVA/15 A	—	

\*1: In the JIS B7721, EN 10002-2, ISO 7500-1, and ASTM E4 standards, an inspection is recommended after the testing machine is installed.

\*2: The crosshead speed accuracy is calculated from the amount of crosshead movement within a specified time at a crosshead speed of 0.5 to 500 mm/min under normal conditions.

\*3: The tensile stroke indicates the value when manual non-shift wedge grips (MWG) or screw-type grips (SCG) are attached.

\*4: During installation, ensure a space of 600 mm on each side and rear of the testing machine for maintenance.

\*5: Internal data sampling rate is 500kHz.

• Values in this catalog have been measured based on separately prescribed test standards.

• If small conductive sample fragments are produced, they might get inside the main unit, resulting in malfunctions. In such a case, contact your Shimadzu representative.

## Options (Adapters for Multi Joint)

	P/N	Description	Remarks
For 20 kN	336-01661-01	Compression Adapter, 20 kN	Boss dia. 22
	336-01664-01	Tensile Compression Adapter, 20 kN	Thread dia. M18 × 1.5
	336-01663-01	5 kN Max. Load Cell Adapter, 20 kN	M12 cell bolt provided
	336-01663-02	10 kN Load Cell Adapter, 20 kN	M18 cell bolt provided
	336-01662-01	Universal Adapter, 20 kN	Connection dia. 25
For 50 kN	336-01661-11	Compression Adapter, 50 kN	Boss dia. 22
	336-01664-11	Tensile Compression Adapter, 50 kN	Thread dia. M26 × 2
	336-01663-11	5 kN Max. Load Cell Adapter, 50 kN	M12 cell bolt provided
	336-01663-12	10 kN Load Cell Adapter, 50 kN	M18 cell bolt provided
	336-01662-11	Universal Adapter, 50 kN	Connection dia. 35
For 100 kN	336-01661-21	Compression Adapter, 100 kN	Boss dia. 22
	336-01664-21	Tensile Compression Adapter, 100 kN	Thread dia. M32 × 2
	336-01663-21	5 kN Max. Load Cell Adapter, 100 kN	M12 cell bolt provided
	336-01663-22	10 kN Load Cell Adapter, 100 kN	M18 cell bolt provided
	336-01662-21	Universal Adapter, 100 kN	Connection dia. 50
For 250/ 300 kN	336-01661-31	Compression Adapter, 300 kN	Boss dia. 22
	336-01664-31	Tensile Compression Adapter, 300 kN	Thread dia. M45 × 3
	336-01663-31	5 kN Max. Load Cell Adapter, 300 kN	M12 cell bolt provided
	336-01663-32	10 kN Load Cell Adapter, 300 kN	M18 cell bolt provided
	336-01662-31	Universal Adapter, 300 kN	Connection dia. 70

## Testing & Inspection

High-Speed Video Camera  
HyperVision HPV-X2



Micro Vickers Hardness Tester  
HMV-G Series



Hydraulic Universal Testing Machines  
UH-X/FX Series



Shimadzu Corporation  
[www.shimadzu.com/an/](http://www.shimadzu.com/an/)

**For Research Use Only. Not for use in diagnostic procedures.**

This publication may contain references to products that are not available in your country. Please contact us to check the availability of these products in your country.

Company names, products/service names and logos used in this publication are trademarks and trade names of Shimadzu Corporation, its subsidiaries or its affiliates, whether or not they are used with trademark symbol "TM" or "®".

Third-party trademarks and trade names may be used in this publication to refer to either the entities or their products/services, whether or not they are used with trademark symbol "TM" or "®".

Shimadzu disclaims any proprietary interest in trademarks and trade names other than its own.

The contents of this publication are provided to you "as is" without warranty of any kind, and are subject to change without notice. Shimadzu does not assume any responsibility or liability for any damage, whether direct or indirect, relating to the use of this publication.